

With pneumatic and electric actuators

**ARI-STEVI® 448 / 449**

**Pneumatic actuator**

**ARI-DP 30-34**

- Reversible pneumatic actuator
- Actuator with rolling diaphragm
- Air supply pressure min. 4 bar
- Air supply pressure max. 6 bar
- Stem protection by bellow
- Maintenance-free O-ring sealing
- Assembly of additional devices acc. to DIN IEC 60534-6

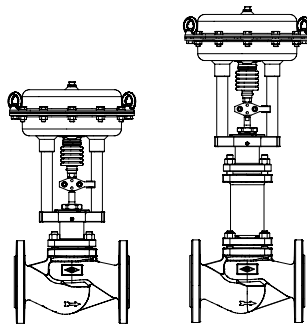

Page 4



Fig.448

**ARI-STEVI® 448 / 449**

**Electric actuator**

**ARI-PREMIO-Plus 2G 2,2-15kN**

- Digital actuator control
- BLDC-Engine technology
- Energy-efficient
- Enclosure IP 65
- 2 torque switches
- Handwheel
- Additional devices available, e.g. potentiometer

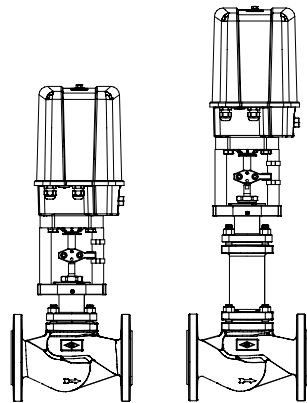

Page 7



Fig. 449

**Features:**

- Compact design
- Bonnet with rotatable traverse
- Optional: Perforated plug for noise reduction
- Replaceable seat
- Reduceable Kvs-values
- Shaft plug guide

Figure	Nominal pressure	Material	Nominal diameter
12.448	PN16	EN-JL1040	DN15-100
22.448 / 22.449	PN16	EN-JS1049	DN15-100
23.448 / 23.449	PN25	EN-JS1049	DN15-100
25.448	PN40	EN-JS1049	DN15-50
32.448 / 32.449	PN16	1.0619+N	DN15-100
34.448 / 34.449	PN25	1.0619+N	DN15-100
35.448 / 35.449	PN40	1.0619+N	DN15-100
52.448 / 52.449	PN16	1.4408	DN15-100
54.448 / 54.449	PN25	1.4408	DN15-100
55.448 / 55.449	PN40	1.4408	DN15-100

Information / restriction of technical rules need to be observed!

A production permission acc. to TRB 801 No. 45 is available.

(acc. to TRB 801 No. 45 EN-JL1040 is not allowed.)

The engineer, designing a system or a plant, is responsible for the selection of the correct valve.

Resistance and fitness must be verified, contact manufacturer for information (refer to Product overview and Resistance list).

Other materials and versions on request.

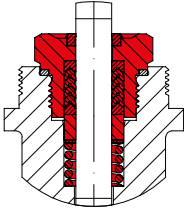
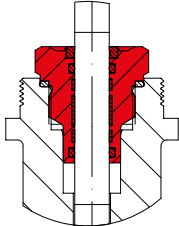
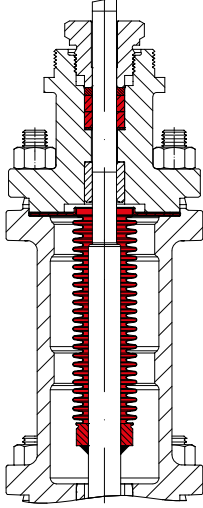
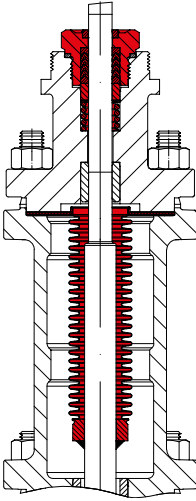
Stem sealing		
Fig. 448	<p><b>standard</b></p>  <p>I. PTFE-V-ring unit -10°C to 220°C</p>	<p><b>optional</b></p>  <p>I. EPDM-sealing -10°C to 150°C (allowed for water and steam up to 180°C)</p>
	<p><b>Fig. 449</b></p>  <p>III. Stainless steel-bellow with pure graphite-packing -60°C to 400°C</p>	 <p>III. Stainless steel-bellow with V-ring unit -60°C to 220°C</p>

Pressure-temperature-ratings			Intermediate values for max. permissible operational pressures can be determined by linear interpolation of the given temperature / pressure chart.							
acc. to DIN EN 1092-2			-60°C to <-10°C <sup>1)</sup>	-10°C to 120°C	150°C	200°C	250°C	300°C	350°C	400°C
EN-JL1040	PN16	(bar)	--	16	14,4	12,8	11,2	9,6	--	--
EN-JS1049	PN16	(bar)	--	16	15,5	14,7	13,9	12,8	11,2	--
EN-JS1049	PN25	(bar)	--	25	24,3	23	21,8	20	17,5	--
EN-JS1049	PN40	(bar)	--	40	38,5	36,8	34,8	32	28	--
acc. to manufacturers standard			-60°C to <-10°C <sup>1)</sup>	-10°C to 120°C	150°C	200°C	250°C	300°C	350°C	400°C
1.0619+N	PN25	(bar)	18,7	25	23,9	22	20	17,2	16	14,8
1.0619+N	PN40	(bar)	30	40	38,1	35	32	28	25,7	23,8
acc. to DIN EN 1092-1			-60°C to <-10°C <sup>1)</sup>	-10°C to 100°C	150°C	200°C	250°C	300°C	350°C	400°C
1.4408	PN40	(bar)	40	40	36,3	33,7	31,8	29,7	28,5	27,4

<sup>1)</sup> Valve with extended bonnet, screws and nuts made of A4-70 (at temperatures below -10°C)

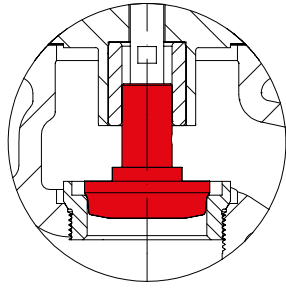
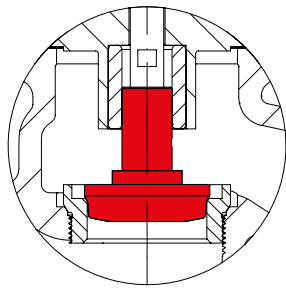
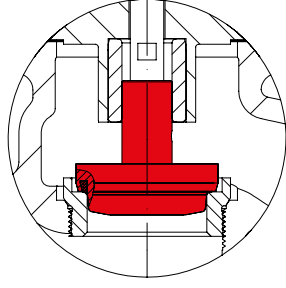
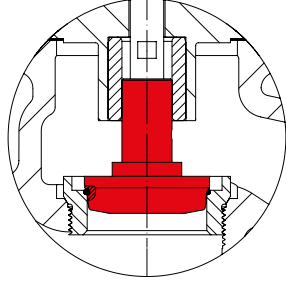
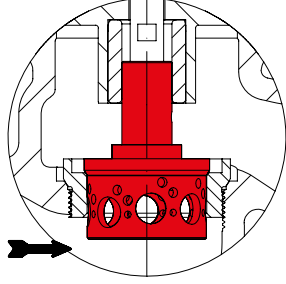
Plug design standard			Guiding	Rangeability
<p><b>Parabolic plug, metal seat</b></p> <ul style="list-style-type: none"> <li>- Leakage class IV acc. to DIN EN 60534-4</li> <li>- from Kvs 0,1</li> <li>- Flow characteristic:               <ul style="list-style-type: none"> <li>- modified equal percentage (glp)</li> <li>- linear (lin)</li> </ul> </li> </ul>		Shaft	50 : 1	
Plug design optional			Guiding	Rangeability
<p><b>Parabolic plug, increased sealing tightness in the seat</b></p> <ul style="list-style-type: none"> <li>- Leakage class IV-S1 acc. to DIN EN 60534-4</li> <li>- metallic polished</li> <li>- from Kvs 0,1</li> <li>- Flow characteristic:               <ul style="list-style-type: none"> <li>- modified equal percentage (glp)</li> <li>- linear (lin)</li> </ul> </li> <li>(special actuator forces necessary, closing pressures on request)</li> </ul>		Shaft	50 : 1	
<p><b>Parabolic plug with PTFE-soft seal (max. 200°C)</b></p> <ul style="list-style-type: none"> <li>- Leakage class VI acc. to DIN EN 60534-4</li> <li>- Flow characteristic:               <ul style="list-style-type: none"> <li>- modified equal percentage (glp)</li> <li>- linear (lin)</li> </ul> </li> </ul>		Shaft	50 : 1	
<p><b>Parabolic plug with armoured sealing edge</b></p> <ul style="list-style-type: none"> <li>- Leakage class IV acc. to DIN EN 60534-4</li> <li>- from Kvs 1</li> <li>- Flow characteristic:               <ul style="list-style-type: none"> <li>- modified equal percentage (glp)</li> <li>- linear (lin)</li> </ul> </li> </ul>		Shaft	50 : 1	
<p><b>Perforated plug metal-seated</b></p> <ul style="list-style-type: none"> <li>- Leakage class IV acc. to DIN EN 60534-4</li> <li>- from Kvs 1</li> <li>- Flow characteristic:               <ul style="list-style-type: none"> <li>- modified equal percentage (glp)</li> <li>- linear (lin)</li> </ul> </li> <li>➡ Flow direction for gases and steam for reduction of the acoustic level</li> </ul>		Shaft / Seat ring	30 : 1	

Control valve in straightway form with pneumatic actuator ARI-DP

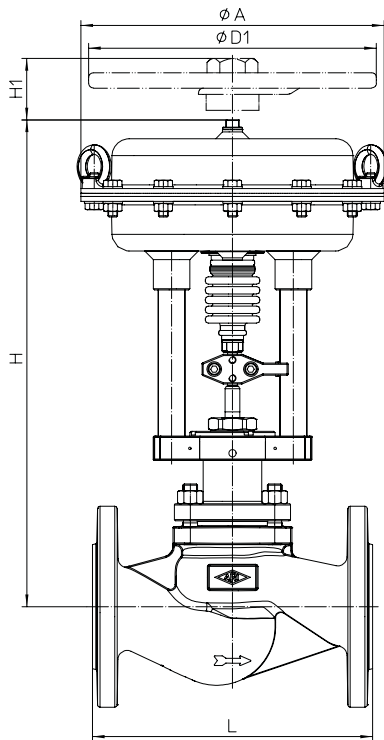

Fig. 448

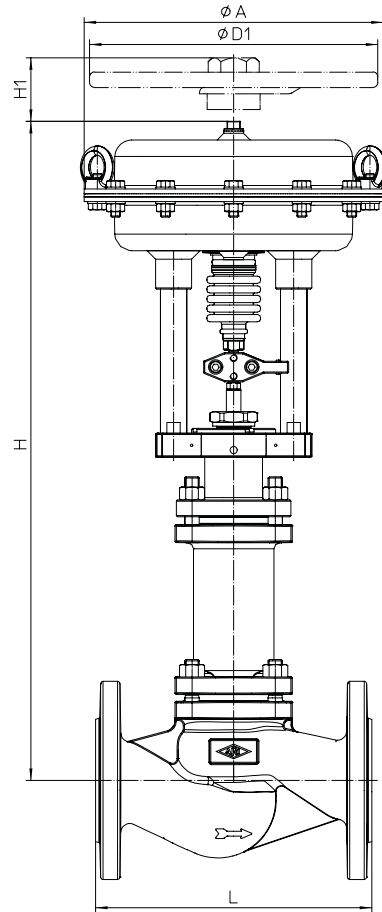

Fig. 449

Technical data		DP30	DP32	DP33	DP34
Actuator	Ø A (mm)	168	250	300	405
	Effective diaphragm area (cm <sup>2</sup> )	80	250	400	800
Top mounted handwheel	Ø D1 (mm)	225	225	300	397
	H1 (mm)	284	284	297	458
	Weight (kg)	5	5	5	17

Technical data for actuator refer to data sheet ARI-DP.

Dimensions and weights

DN		15	20	25	32	40	50	65	80	100	
L	(mm)	130	150	160	180	200	230	290	310	350	
Fig. 448	DP30	H (mm)	354	354	369	369	384	391			
		PN16-40 (kg)	8	9	10	12	14	17			
	DP32	H (mm)				378	393	400	407	429	445
		PN16-40 (kg)				17	19	22	28	35	47
	DP33	H (mm)							458	480	496
		PN16-40 (kg)							34	41	53
DP34	H (mm)							527	549	565	
	PN16-40 (kg)							64	71	83	
Fig. 449	DP30	H (mm)	539	539	547	547	538	540			
		PN16-40 (kg)	14	15	18	20	27	30			
	DP32	H (mm)				556	547	549	633	646	662
		PN16-40 (kg)				25	32	35	41	52	68
	DP33	H (mm)							684	697	713
		PN16-40 (kg)							47	58	74
DP34	H (mm)							753	766	782	
	PN16-40 (kg)							77	88	104	

Other dimensions refer to pages 9.

Technical data for actuator refer to data sheet ARI-DP.



**Spring closes on air failure**  
(stem extended by spring)

**max. permissible closing pressures** on flow-to-open P2 = 0.  
Observe pressure-temperature-limits, refer to page 2.

DN				15			20				25				
Parabolic plug	Kvs-value	(m³/h)		0,25 / 0,16 / 0,1	0,63 / 0,4	4 / 2,5 / 1,6 / 1	0,25 / 0,16 / 0,1	0,63 / 0,4	4 / 2,5 / 1,6 / 1	<b>6,3</b>	0,25 / 0,16 / 0,1	0,63 / 0,4	4 / 2,5 / 1,6 / 1	6,3	<b>10</b>
	max. diff. pressure <sup>1)</sup>	(bar)		40			40				40				
Perforated plug	Kvs-value	(m³/h)		--	--	<b>2,5 / 1,6 / 1</b>	--	--	<b>2,5 / 1,6 / 1</b>	<b>4</b>	--	--	<b>2,5 / 1,6 / 1</b>	<b>4</b>	<b>6,3</b>
	max. diff. pressure <sup>1)</sup>	(bar)		--	--	40	--	--	40		--	--	40		
Seat-Ø			(mm)	3	5	12	3	5	12	16	3	5	12	16	22
Travel			(mm)	10			10				10				
<b>DP30</b> <b>80 cm²</b> <b>(Air supply pressure max.: 6 bar)</b>	Air supply pressure min. (bar)	4	I.	(bar)	40	40	40	40	40	40	40	40	40	40	40
			III.	(bar)	32	32	31	32	32	31	30	32	32	31	30

DN				32				40				50			
Parabolic plug	Kvs-value	(m³/h)		4 / 2,5 / 1,6 / 1	6,3	10	<b>16</b>	6,3	10	16	<b>25</b>	10	16	25	<b>40</b>
	max. diff. pressure <sup>1)</sup>	(bar)		40			40				30	40		30	
Perforated plug	Kvs-value	(m³/h)		2,5 / 1,6 / 1	4	6,3	<b>10</b>	4	6,3	10	<b>16</b>	6,3	10	16	<b>25</b>
	max. diff. pressure <sup>1)</sup>	(bar)		40			40				40				
Seat-Ø			(mm)	12	16	22	28	16	22	28	35	22	28	35	43
Travel			(mm)	10			15	10		15		10	15		
<b>DP30</b> <b>80 cm²</b> <b>(Air supply pressure max.: 6 bar)</b>	Air supply pressure min. (bar)	4	I.	(bar)	40	40	40		40	40			40		
			III.	(bar)	31	30	30		30	30		30			
<b>DP32</b> <b>250 cm²</b> <b>(Air supply pressure max.: 6 bar)</b>	Air supply pressure min. (bar)	4	I.	(bar)			40			40	40		40	40	28
			III.	(bar)			40			40	39		40	39	26

DN				65				80				100				
Parabolic plug	Kvs-value	(m³/h)		16	25	40	<b>63</b>	25	40	63	<b>100</b>	40	63	100	<b>160</b>	
	max. diff. pressure <sup>1)</sup>	(bar)		40	30	30	10	30	30	10	8	30	10	8	3	
Perforated plug	Kvs-value	(m³/h)		10	16	25	<b>40</b>	16	25	40	<b>63</b>	25	40	63	<b>100</b>	
	max. diff. pressure <sup>1)</sup>	(bar)		40			40				40					
Seat-Ø			(mm)	28	35	43	56	35	43	56	70	43	56	70	95	
Travel			(mm)	15			20	15		20	25	15	20	25	30	
<b>DP32</b> <b>250 cm²</b> <b>(Air supply pressure max.: 6 bar)</b>	Air supply pressure min. (bar)	4	I.	(bar)	40	40	28		40	28		28				
			III.	(bar)	40	39	26		39	26		26				
<b>DP33</b> <b>400 cm²</b> <b>(Air supply pressure max.: 6 bar)</b>	Air supply pressure min. (bar)	4	I.	(bar)			40	25		40	25	16	40	25	16	8
			III.	(bar)			40	24		40	24	15	40	24	15	8
<b>DP34</b> <b>800 cm²</b> <b>(Air supply pressure max.: 4 bar)</b>	Air supply pressure min. (bar)	4	I.	(bar)			40			40	32		40	32	17	
			III.	(bar)			40			40	31		40	31	16	

I. Fig. 448: PTFE-V-ring unit / EPDM-sealing  
III. Fig. 449: Bellows seal

<sup>1)</sup> max. differential pressure drop



**Spring opens on air failure**  
(stem retracting by spring)

**max. permissible closing pressures** on flow-to-open P2 = 0.  
Observe pressure-temperature-limits, refer to page 2.

DN			15					20				25								
Parabolic plug	Kvs-value	(m³/h)	0,25 / 0,16 / 0,1	0,63 / 0,4	4 / 2,5 / 1,6 / 1	0,25 / 0,16 / 0,1	0,63 / 0,4	4 / 2,5 / 1,6 / 1	6,3	0,25 / 0,16 / 0,1	0,63 / 0,4	4 / 2,5 / 1,6 / 1	6,3	10						
	max. diff. pressure <sup>1)</sup>	(bar)	40					40				40								
Perforated plug	Kvs-value	(m³/h)	--	--	2,5 / 1,6 / 1	--	--	2,5 / 1,6 / 1	4	--	--	2,5 / 1,6 / 1	4	6,3						
	max. diff. pressure <sup>1)</sup>	(bar)	--	--	40	--	--	40	--	--	40	--	40							
Seat-Ø			3		5		12		16		3		5		12		16		22	
Travel			10					10				10								
DP30 80 cm² (Air supply pressure max.: 6 bar)	Air supply pressure min. (bar)	2	I.	(bar)	40	40	33	40	40	33	18	40	40	33	18	8				
			III.	(bar)	5	4	3	5	4	3	3	5	4	3	3	2				
		3	I.	(bar)			40			40	40			40	40	28				
			III.	(bar)	19	19	18	19	19	18	17	19	19	18	17	16				
		4	I.	(bar)												40				
			III.	(bar)	33	33	32	33	33	32	31	33	33	32	31	31				

DN			32					40				50								
Parabolic plug	Kvs-value	(m³/h)	4 / 2,5 / 1,6 / 1	6,3	10	16	6,3	10	16	25	10	16	25	40						
	max. diff. pressure <sup>1)</sup>	(bar)	40					40				30	40		30					
Perforated plug	Kvs-value	(m³/h)	2,5 / 1,6 / 1	4	6,3	10	4	6,3	10	16	6,3	10	16	25						
	max. diff. pressure <sup>1)</sup>	(bar)	40					40				40								
Seat-Ø			12		16		22		28		16		22		28		35		43	
Travel			10					15				10		15		10				
DP30 80 cm² (Air supply pressure max.: 6 bar)	Air supply pressure min. (bar)	2	I.	(bar)	33	18	8		18	8			8							
			III.	(bar)	3	3	2	3	2			2								
		3	I.	(bar)	40	40	28	40	28			28								
			III.	(bar)	18	17	16	17	16			16								
		4	I.	(bar)			40			40			40							
			III.	(bar)	32	31	31	31	31			31								
DP32 250 cm² (Air supply pressure max.: 4 bar)	Air supply pressure min. (bar)	2	I.	(bar)	40	40	38	23	40	38	23	14	38	23	14	9				
			III.	(bar)	25	25	24	19	25	24	19	11	24	19	11	7				
		3	I.	(bar)			40	40		40	40	36	40	40	36	23				
			III.	(bar)			40	40		40	40	33	40	40	33	21				
		4	I.	(bar)								40			40	38				
			III.	(bar)								40			40	36				

DN			65					80				100								
Parabolic plug	Kvs-value	(m³/h)	16	25	40	63	25	40	63	100	40	63	100	160						
	max. diff. pressure <sup>1)</sup>	(bar)	40	30	30	10	30	30	10	8	30	10	8	3						
Perforated plug	Kvs-value	(m³/h)	10	16	25	40	16	25	40	63	25	40	63	100						
	max. diff. pressure <sup>1)</sup>	(bar)	40					40				40								
Seat-Ø			28		35		43		56		35		43		56		70		95	
Travel			15					20				15		20		25				
DP32 250 cm² (Air supply pressure max.: 6 bar)	Air supply pressure min. (bar)	2	I.	(bar)	22	14	8		14	8			8							
			III.	(bar)	18	11	7	11	7			7								
		3	I.	(bar)	40	36	23	40	36	23			23							
			III.	(bar)	40	33	21	33	21			21								
		4	I.	(bar)			40	38	40	38			38							
			III.	(bar)			40	36	40	36			36							
5	I.	(bar)			40			40			40									
	III.	(bar)			40			40			40									
DP33 400 cm² (Air supply pressure max.: 5 bar)	Air supply pressure min. (bar)	2	I.	(bar)	40	30	20	11	30	20	11	7	20	11	7	3				
			III.	(bar)	40	28	18	10	28	18	10	6	18	10	6	3				
		3	I.	(bar)			40	40	26	40	40	26	17	40	26	17	9			
			III.	(bar)			40	40	25	40	40	25	16	40	25	16	8			
		4	I.	(bar)				40			40	26			40	26	14			
			III.	(bar)				40			40	26			40	26	14			
5	I.	(bar)								36			36	19						
	III.	(bar)								36			36	19						

I. Fig. 448: PTFE-V-ring unit / EPDM-sealing

III. Fig. 449: Bellows seal

<sup>1)</sup> max. differential pressure drop

Control valve in straightway form with electric actuator PREMIO-Plus 2G

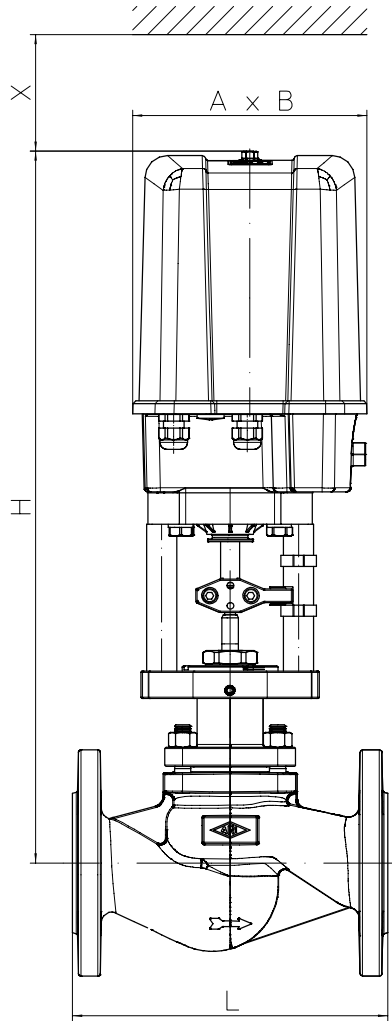

Fig. 448

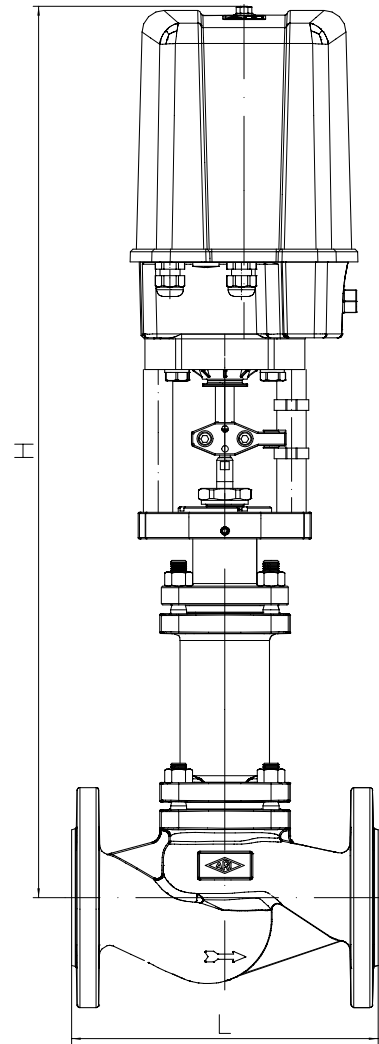

Fig. 449

Actuator data		2,2 - 5 kN	15 kN
A	(mm)	171	210
B	(mm)	156	184
X	(mm)	150	200

Technical data for actuator refer to data sheet PREMIO-Plus 2G

Dimensions and weights

DN	15	20	25	32	40	50	65	80	100			
L	(mm)	130	150	160	180	200	230	290	310	350		
Fig. 448	2,2 kN	H	(mm)	496	496	511	511	526	533			
		PN16-40	(kg)	10	11	12	14	16	19			
	5 kN	H	(mm)	496	496	511	511	526	533	550	572	588
		PN16-40	(kg)	10	11	12	14	16	19	25	32	44
	15 kN	H	(mm)							667	689	705
		PN16-40	(kg)							29	36	48
Fig. 449	2,2 kN	H	(mm)	681	681	689	689	680	682			
		PN16-40	(kg)	16	17	20	22	29	32			
	5 kN	H	(mm)	681	681	689	689	680	682	776	789	805
		PN16-40	(kg)	16	17	20	22	29	32	38	49	65
	15 kN	H	(mm)							893	906	922
		PN16-40	(kg)							42	53	69

Other dimensions refer to pages 9.

max. permissible closing pressures on flow-to-open P2 = 0.  
Observe pressure-temperature-limits, refer to page 2.

DN			15				20				25					
Parabolic plug	Kvs-value	(m³/h)	0,25 / 0,16 / 0,1	0,63 / 0,4	4 / 2,5 / 1,6 / 1	0,25 / 0,16 / 0,1	0,63 / 0,4	4 / 2,5 / 1,6 / 1	6,3	0,25 / 0,16 / 0,1	0,63 / 0,4	4 / 2,5 / 1,6 / 1	6,3	10		
	max. diff. pressure <sup>1)</sup>	(bar)	40				40				40					
Perforated plug	Kvs-value	(m³/h)	--	--	2,5 / 1,6 / 1	--	--	2,5 / 1,6 / 1	4	--	--	2,5 / 1,6 / 1	4	6,3		
	max. diff. pressure <sup>1)</sup>	(bar)	--	--	40	--	--	40	--	--	40	--	--	40		
Seat-Ø		(mm)	3	5	12	3	5	12	16	3	5	12	16	22		
Travel		(mm)	10				10				10					
2,2 kN	Closing pressure	I.	(bar)	40	40	40	40	40	40	40	40	40	40	40		
		III.	(bar)	33	32	31	33	32	31	31	33	32	31	31	30	
	Operating time		(s)	40				40				40				
	Operating speed		(mm/s)	0,25				0,25				0,25				

DN			32				40				50				
Parabolic plug	Kvs-value	(m³/h)	4 / 2,5 / 1,6 / 1	6,3	10	16	6,3	10	16	25	10	16	25	40	
	max. diff. pressure <sup>1)</sup>	(bar)	40				40				30	40		30	
Perforated plug	Kvs-value	(m³/h)	2,5 / 1,6 / 1	4	6,3	10	4	6,3	10	16	6,3	10	16	25	
	max. diff. pressure <sup>1)</sup>	(bar)	40				40				40				
Seat-Ø		(mm)	12	16	22	28	16	22	28	35	22	28	35	43	
Travel		(mm)	10				15				10		15		
2,2 kN	Closing pressure	I.	(bar)	40	40	40	28	40	40	28	17	40	28	17	11
		III.	(bar)	31	31	30	25	31	30	25	14	30	25	14	9
	Operating time		(s)	40				60				40		60	
	Operating speed		(mm/s)	0,25				0,25				0,25			
5 kN	Closing pressure	I.	(bar)			40			40	40		40	40	30	
		III.	(bar)			40			40	40		40	40	28	
	Operating time		(s)			60			60			60		60	
	Operating speed		(mm/s)			0,25			0,25			0,25		0,25	

DN			65				80				100				
Parabolic plug	Kvs-value	(m³/h)	16	25	40	63	25	40	63	100	40	63	100	160	
	max. diff. pressure <sup>1)</sup>	(bar)	40	30	30	10	30	30	10	8	30	10	8	3	
Perforated plug	Kvs-value	(m³/h)	10	16	25	40	16	25	40	63	25	40	63	100	
	max. diff. pressure <sup>1)</sup>	(bar)	40				40				40				
Seat-Ø		(mm)	28	35	43	56	35	43	56	70	43	56	70	95	
Travel		(mm)	15				20				15		20		
5 kN	Closing pressure	I.	(bar)	40	40	29	17	40	29	17	10	29	17	10	5
		III.	(bar)	40	40	28	16	40	28	16	10	28	16	10	5
	Operating time		(s)	39				53				39		53	
	Operating speed		(mm/s)	0,38				0,38				0,38			
15 kN	Closing pressure	I.	(bar)			40	40		40	40	36	40	40	36	19
		III.	(bar)			40	40		40	40	35	40	40	35	19
	Operating time		(s)			39	53		39	53	66	39	53	66	79
	Operating speed		(mm/s)			0,38			0,38			0,38			0,38

Further operating speeds: refer to data sheet PREMIO-Plus 2G

Operating time [s]=	Travel [mm]
	Operating speed [mm/s]

I. Fig. 448: PTFE-V-ring unit / EPDM-sealing  
III. Fig. 449: Bellows seal

<sup>1)</sup> max. differential pressure drop



Control valve in straightway form

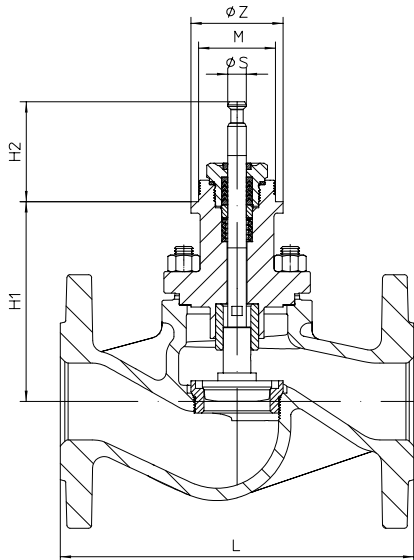

Fig. 448

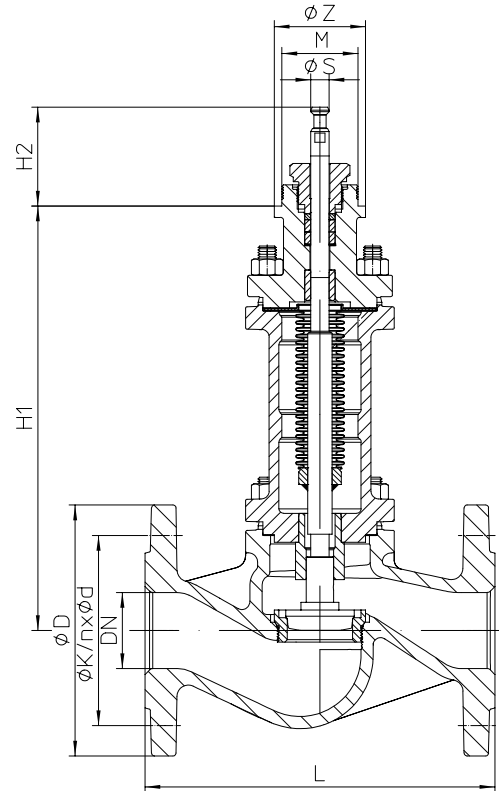
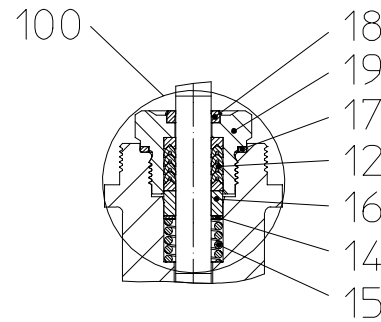
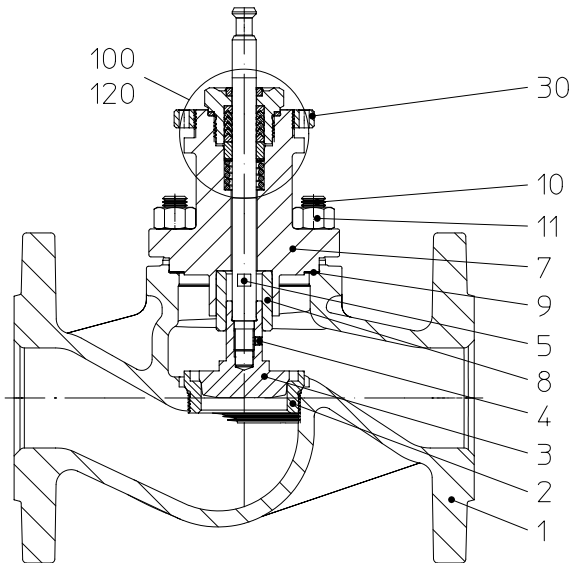
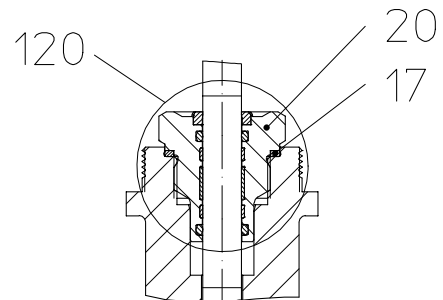

Fig. 449

DN	15	20	25	32	40	50	65	80	100		
<b>Dimensions</b>											
M	Fig. 448 / Fig. 449	(mm)	M50 x 1,5								
ØZ	Fig. 448 / Fig. 449	(mm)	60								
ØS	Fig. 448 / Fig. 449	(mm)	12				16				
H1	Fig. 448	(mm)	93	108	123	130	137	159	175		
	Fig. 449	(mm)	278	286	277	279	363	376	392		
H2	Fig. 448 / Fig. 449	(mm)	65								
<b>Face-to-face dimension FTF series 1 acc. to DIN EN 558</b>											
L	(mm)	130	150	160	180	200	230	290	310	350	
<b>Flanges acc. to DIN EN 1092-1-2</b>			<b>Flange holes / -thickness tolerances acc. to DIN 2533/2544/2545</b>								
ØD	PN16	(mm)								220	
	PN25	(mm)	95	105	115	140	150	165	185	200	235
	PN40	(mm)									
ØK	PN16	(mm)								180	
	PN25	(mm)	65	75	85	100	110	125	145	160	190
	PN40	(mm)									
n x Ød	PN16	(mm)	4 x 14			4 x 18		4 x 18	8 x 18	8 x 18	
	PN25	(mm)	4 x 14			4 x 18		8 x 18		8 x 22	
	PN40	(mm)	4 x 14			4 x 18		8 x 18	8 x 22		
<b>Weight</b>											
Fig. 448	PN16-40	(kg)	4	5	6	8	10	13	19	26	38
Fig. 449	PN16-40	(kg)	10	11	14	16	23	26	32	43	59
<b>max. permissible thrust</b>											
Fig. 448		(kN)	5			7,5		15			
Fig. 449		(kN)	5			7,5		15			



I. PTFE-V-ring unit



I. EPDM-sealing

Pos.	Sp.p..	Description	Fig. 12.448	Fig. 22./23./25.448	Fig. 34./35.448	Fig. 55.448
1		Body	EN-GJL-250 , EN-JL1040	EN-GJS-400-18U-LT, EN-JS1049	GP240GH+N, 1.0619+N	GX5CrNiMo19-11-2, 1.4408
2	x	Seat ring	X20Cr13+QT, 1.4021+QT			X6CrNiMoTi17-12-2, 1.4571
3	x	Plug	X20Cr13+QT, 1.4021+QT			X6CrNiMoTi17-12-2, 1.4571
4	x	Thread pin	A4			
5	x	Stem	X20Cr13+QT, 1.4021+QT			X6CrNiMoTi17-12-2, 1.4571
7		Bonnet	GP240GH+N, 1.0619+N			GX5CrNiMo19-11-2, 1.4408
8		Guide bushing	X20Cr13+QT, 1.4021+QT (hardened)			X6CrNiMoTi17-12-2, 1.4571 (hardened)
9	x	Gasket	pure graphite (CrNi laminated with graphite)			
10		Stud	25CrMo4, 1.7218			A4 - 70
11		Hexagon nuts	C35E, 1.1181			A4
12	Set: refer to Pos. 100	V-ring unit	PTFE / Graphite			
14		Washer	X5CrNi18-10, 1.4301			
15		Compression spring	X10CrNi18-8, 1.4310			
16		Bush	PTFE (strengthened)			
17		Gasket	X6CrNiMoTi17-12-2, 1.4571			
18		Scraper	PTFE (strengthened)			
19		Screw joint	X8CrNiS18-9, 1.4305			
20		Screw joint	X8CrNiS18-9, 1.4305 / EPDM			
30	x	Central nut	X8CrNiS18-9, 1.4305			

**Stem sealing Fig. 448**

100	x	V-ring unit set	Set aus: Pos. 12, 14, 15, 16, 17, 18, 19
120	x	EPDM-sealing set	Set aus: Pos. 17, 20
		L Spare parts	

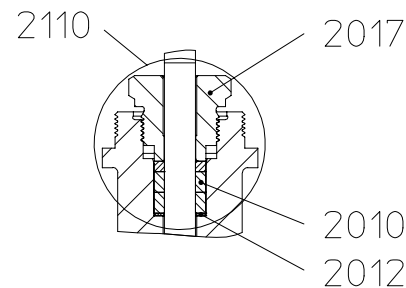
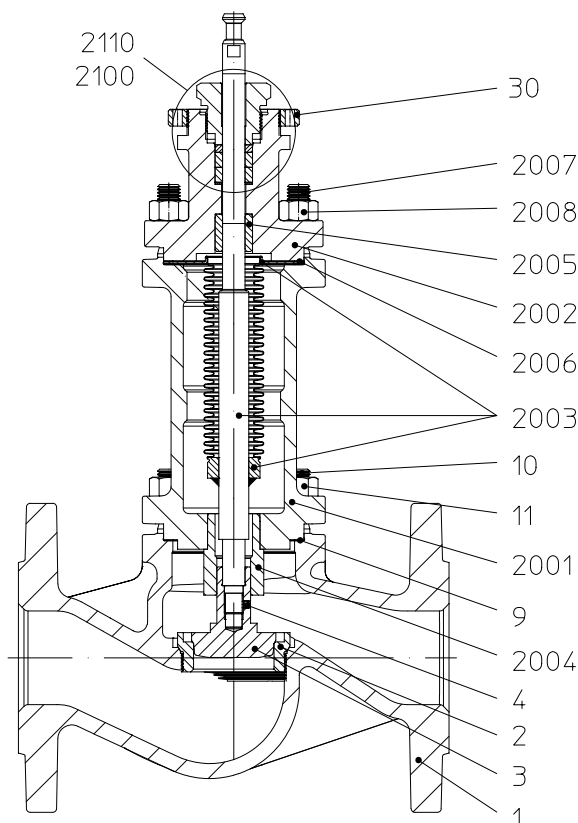

III. Stainless steel-bellow with pure graphite-packing

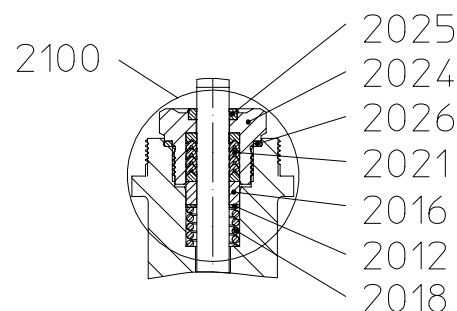

III. Stainless steel-bellow with V-ring unit

Pos.	Sp.p.	Description	Fig. 22./23.449	Fig. 34./35.449	Fig. 55.449
1		Body	EN-GJS-400-18U-LT, EN-JS1049	GP240GH+N, 1.0619+N	GX5CrNiMo19-11-2, 1.4408
2	x	Seat ring	X20Cr13+QT, 1.4021+QT		X6CrNiMoTi17-12-2, 1.4571
3	x	Plug	X20Cr13+QT, 1.4021+QT		X6CrNiMoTi17-12-2, 1.4571
4	x	Thread pin	A4		
9	x	Gasket	Pure graphite (CrNi laminated with graphite)		
10		Stud	25CrMo4, 1.7218		A4 - 70
11		Hexagon nuts	C35E, 1.1181		A4
30	x	Central nut	X8CrNiS18-9, 1.4305		
2001		Bellows housing	EN-GJS-400-18U-LT, EN-JS1049	GP240GH+N, 1.0619+N	GX5CrNiMo19-11-2, 1.4408
2002		Bonnet	GP240GH+N, 1.0619+N		
2003	x	Stem- / Bellows unit	X20Cr13+QT, 1.4021+QT / X6CrNiTi18-10, 1.4541		X6CrNiMoTi17-12-2, 1.4571
2004		Guide bushing	X20Cr13+QT, 1.4021+QT (hardened)		
2005		Guide bushing	X20Cr13+QT, 1.4021+QT (hardened)		
2006	x	Gasket	Pure graphite (CrNi laminated with graphite)		
2007		Stud	25CrMo4, 1.7218		A4 - 70
2008		Hexagon nuts	C35E, 1.1181		A4
2010	Set refer to Pos. 2110	Packing ring	Pure graphite		
2012		Washer	X5CrNi18-10, 1.4301		
2017		Screw joint	X8CrNiS18-9, 1.4305		
2016	Set refer to Pos. 2100	Bush	PTFE (strengthened (only for DN15-50))		
2018		Compression spring	X10CrNi18-8, 1.4310		
2021		V-ring unit	PTFE / Graphite		
2024		Screw joint	X8CrNiS18-9, 1.4305		
2025		Scraper	PTFE		
2026		Gasket	X6CrNiMoTi17-12-2, 1.4571		

**Stem sealings Fig. 449**

2110	x	Packing rings set	Set of: Pos. 2010, 2012, 2017
2100	x	V-ring unit set	Set of: Pos. 2012, 2016, 2018, 2021, 2024, 2025, 2026
		L Spare parts	

